

Models 5321C and 5322C

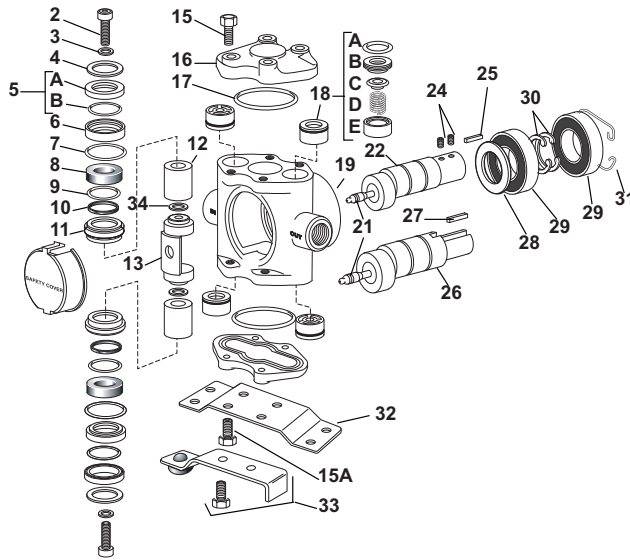

Plunger Parts Kits

Plunger Stack Parts Kit No. 3430-0144 (Model 5321)

Consists of two each of the following parts: No. 1440-0010 Seal Rings, No. 1440-0037 Guides, No. 1720-0064 O-rings, No. 1720-0079 O-rings, No. 2150-0027 Seal Assemblies, No. 2220-0039 Socket Head Cap Screws, and No. 2270-0042 Washers.

Plunger Parts Kit No. 3430-0145 (Model 5321)

Consists of one No. 3430-0144 Plunger Stack Parts Kit and two No. 3500-0021 Plungers.

Plunger Stack Parts Kit No. 3430-0291 (Model 5322)

Consists of two each of the following parts: No. 1440-0010 Seal Rings, No. 1440-0037 Guides, No. 1720-0064 O-rings, No. 1720-0079 O-rings, No. 2150-0027 Seal Assemblies, No. 2220-0039 Socket Head Cap Screws, and No. 2270-0042 Washers.

Plunger Parts Kit No. 3430-0292 (Model 5322)

Consists of one No. 3430-0291 Plunger Stack Parts Kit and two No. 3500-0036 Plungers.

Crankshaft Assemblies

Solid Shaft Sub-Assembly No. 5001-5321

Consists of one each of the following parts: No. 0500-5321 Crankshaft, No. 1600-0014 Crankpin Retainer, No. 2007-0029 Cam Bearing, No. 2405-0006 Grease Fitting Assembly, and No. 1610-0007 Key.

Hollow Shaft Sub-Assembly No. 5501-5321

Consists of one No. 0550-5321 Crankshaft, one No. 2007-0029 Cam Bearing, one No. 2405-0006 Grease Fitting Assembly, one No. 1610-0011 Key, and two No. 2230-0017 Set Screws.

Hollow Shaft Assembly No. 5500-5321

Consists of one No. 5501-5321 Crankshaft Sub-Assembly, two No. 1810-0013 Retaining Rings, two No. 2008-0001 Main Bearings, and one No. 2130-0007 Bearing Shield.

Ref. No.	Qty. Req'd.	Part No.	Description
2	2	2220-0039	Socket Head Cap Screw
3	2	2270-0042	Washer
4	2	1830-0056	Retainer
5	2	2150-0027	Seal Assembly: Consists of No. 2150-0049 Seal (Ref. A) and No. 1440-0061 Support Ring (Ref. B)
6	2	1830-0054	Seal Retainer
7	2	1720-0079	O-ring for Seal Retainer
8	2	1440-0037	Guide
9	2	1720-0064	O-ring for Seal Ring
10	2	1440-0010	Seal Ring
11	2	1830-0053	Guide Retainer
12	2	3500-0021	Plunger (steel, Model 5321)
12	2	3500-0036	Plunger (ceramic, Model 5322)
13	1	0502-5300	Connecting Rod (Model 5321)
13	1	0504-5300	Connecting Rod (Model 5322)
14	1	0608-5300	Safety Cover
15	*	2210-0063	Cylinder Head Seal Bolt (8 bolts required for Model 5321C-H Hollow Shaft Pump; 4 bolts required for Top Cylinder Head ONLY on Solid Shaft Pumps)
15A	4	2210-0064	Extra Long Cylinder Head Bolt for securing mounting base to Solid Shaft Models
16	2	0201-5300C	Cylinder Head (Cast Iron)
17	2	1720-0038	O-ring for Cylinder Head
18	1 set	3430-0197	Set of four No. 3400-0073 Unitized Valve Assemblies: Consists of four each: O-ring (Ref. A), Valve Seat (Ref. B), Valve Poppet (Ref. C), Valve Spring (Ref. D), and Valve Spring Retainer (Ref. E)

Ref. No.	Qty. Req'd.	Part No.	Description
19	1	0108-5300C	Body (Cast Iron)
21	1	2405-0006	Grease Fitting
22	1		Hollow Shaft Sub-Assembly (see listing above)
24	2	2230-0017	Set Screws for Hollow Shaft
25	1	1610-0011	Spline Key for Hollow Shaft
26	1		Solid Shaft Sub-Assembly (see listing above)
27	1	1610-0007	Spline Key for Solid Shaft
28	1	2130-0007	Shield
29	2	2008-0001	Main Bearing
30	2	1810-0013	Retaining Ring (shaft)
31	1	1820-0025	Retaining Ring (housing)
32	1	1510-0041	Mounting Base for Solid Shaft Models
33	1	3420-0030	Torque Arm Kit for Hollow Shaft Models - Consists of No. 2820-0035 Torque Arm, No. 1450-0003 Bumper and two No. 2210-0064 Bolts
34	2	2270-0097	Washer (Model 5322 only)