

# Models 1550, 1550-SP, 1550-BSP, 1551, 1551-SP, 1551-BSP, 1552C-130, 1552C-130E

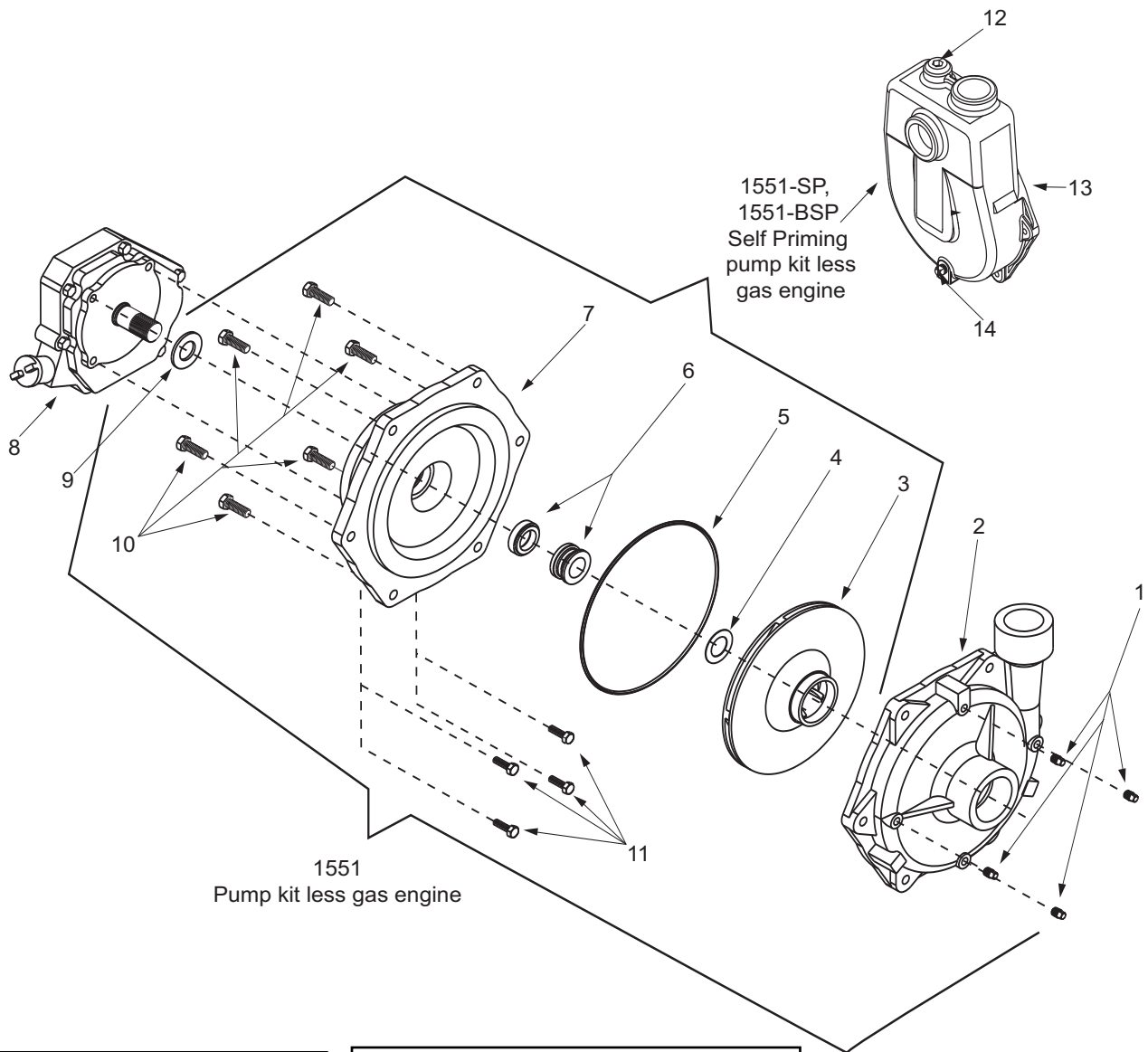

Seal Kit No. 3430-0464 for 1550, 1551 and 1552 consists of:

- (1) Ref. 4 Gasket
- (1) Ref. 5 O-ring
- (1) Ref. 6 Mechanical Seal

**Note:** When ordering parts, give quantity, part number, description and complete model number. Reference numbers are used ONLY to identify parts in the drawing and NOT to be used as order numbers.

Ref. No.	Qty. Req'd.	Part No.	Description
1	4	2406-0007	Drain Plug
2	1	0153-9200C	Pump Casing (includes SS wear ring)
3	1	0404-9200P	Impeller (Nylon)
4	1	1700-0121	Gasket
5	1	1720-0180	O-ring
6	1	2120-0034	Mechanical Seal - Viton
7	1	0707-9200C	Flange
8	1	2541-0037	Honda engine (1550) (GX-270PA)*
8	1	2541-0050	13 HP PowerPro

Ref. No.	Qty. Req'd.	Part No.	Description
8	1	2541-0051	13 HP PowerPro (Electric start)
9	1	1410-0091	Slinger Ring
10	6	2210-0086	Bolt
11	4	2210-0098	Bolt
12	1	2406-0034	Priming Port Plug (Standard)
12	1	2406-0036	Priming Port Plug (BSP)
13	1	0152-9075C	Pump Casing (Standard NPT)
13	1	0152-9075C1	Pump Casing (BSP)
14	1	2406-0002	Drain Plug

\* Contact the Engine Manufacturer for this Product Number.

1550 Based on 9.0 HP Honda						English Standard
GPM at 20 PSI	GPM at 40 PSI	GPM at 60 PSI	GPM at 80 PSI	GPM at 100 PSI	GPM at 120 PSI	GPM at 140 PSI
145	130	107	87	69	45	16

1550 Based on 9.0 HP Honda						Metric
LPM at 1.4 BAR	LPM at 2.8 BAR	LPM at 4.1 BAR	LPM at 5.5 BAR	LPM at 6.9 BAR	LPM at 8.3 BAR	LPM at 9.7 BAR
549	492	405	329	261	170	61

1550SP Based on 9.0 HP Honda						English Standard
GPM at 10 PSI	GPM at 20 PSI	GPM at 40 PSI	GPM at 60 PSI	GPM at 80 PSI	GPM at 100 PSI	GPM at 120 PSI
145	141	118	93	71	49	28

1550SP Based on 9.0 HP Honda						Metric
LPM at 0.7 BAR	LPM at 1.4 BAR	LPM at 2.1 BAR	LPM at 2.8 BAR	LPM at 3.4 BAR	LPM at 4.1 BAR	LPM at 4.8 BAR
549	534	447	352	269	185	106

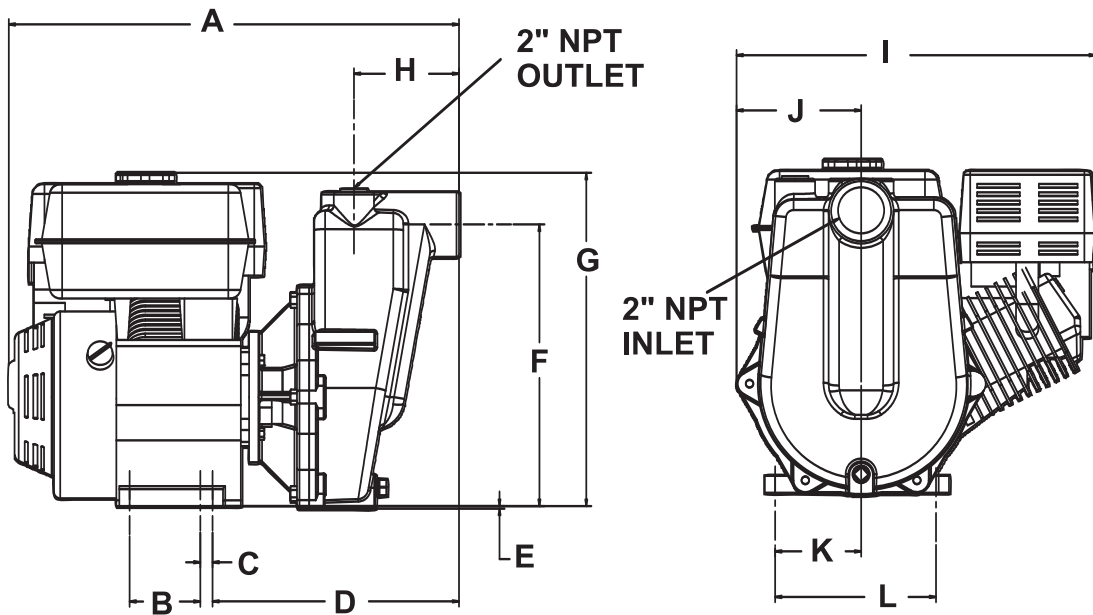

1550SP		
Dimensions		
	Inches	mm
A	21.69	550.9
B	3.41	86.6
C	0.59	15.0
D	11.87	301.5
E	0.13	3.3
F	13.56	344.4
G	16.05	407.7
H	5.06	128.5
I	17.30	65.0
J	6.00	152.4
K	4.14	105.2
L	7.75	196.9

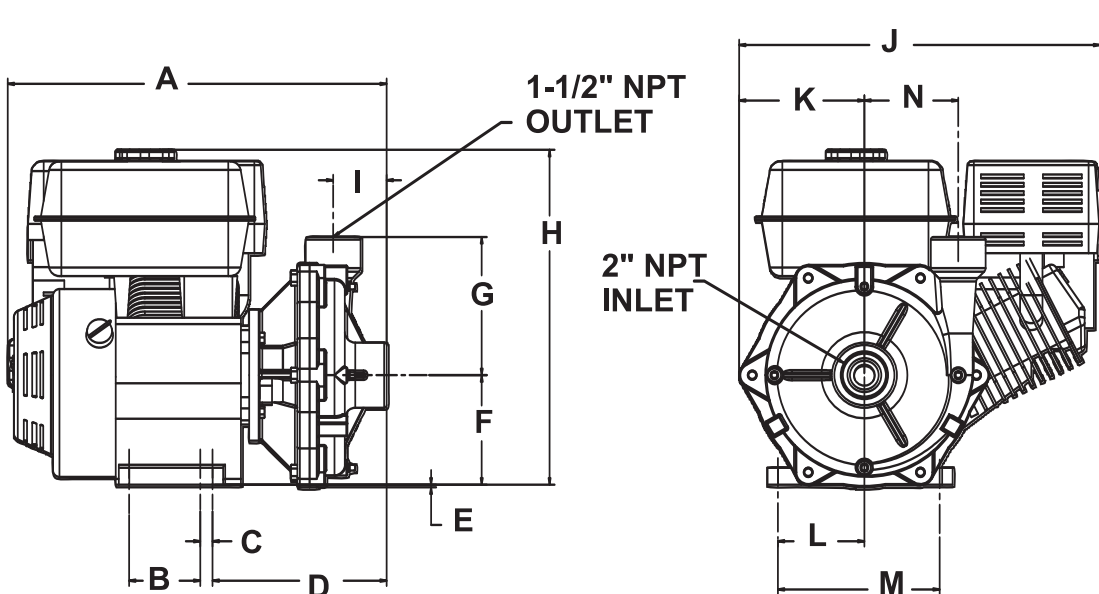

1550		
Dimensions		
	Inches	mm
A	18.16	461.3
B	3.41	86.6
C	0.59	15.0
D	8.34	211.8
E	0.13	3.3
F	5.25	133.4
G	6.63	168.4
H	16.05	407.7
I	2.56	65.0
J	17.30	439.4
K	6.00	152.4
L	4.14	105.2
M	7.75	196.9
N	4.50	114.3