

# Parts Illustrations for Model 9910-D1516

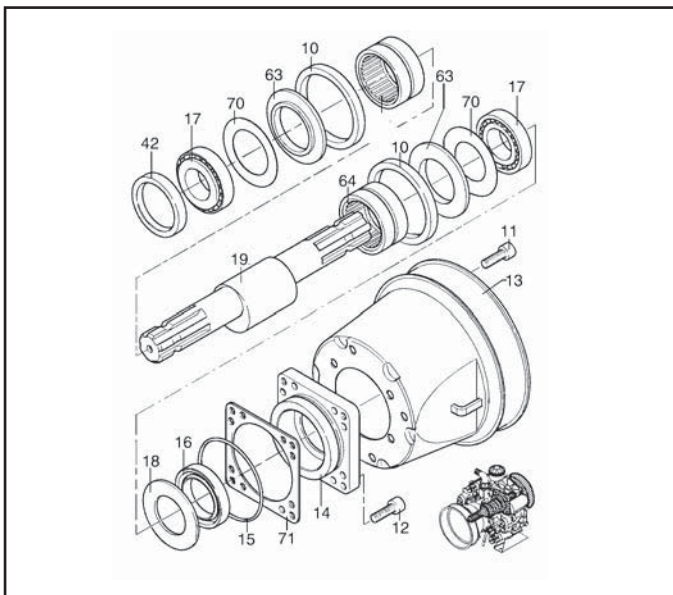
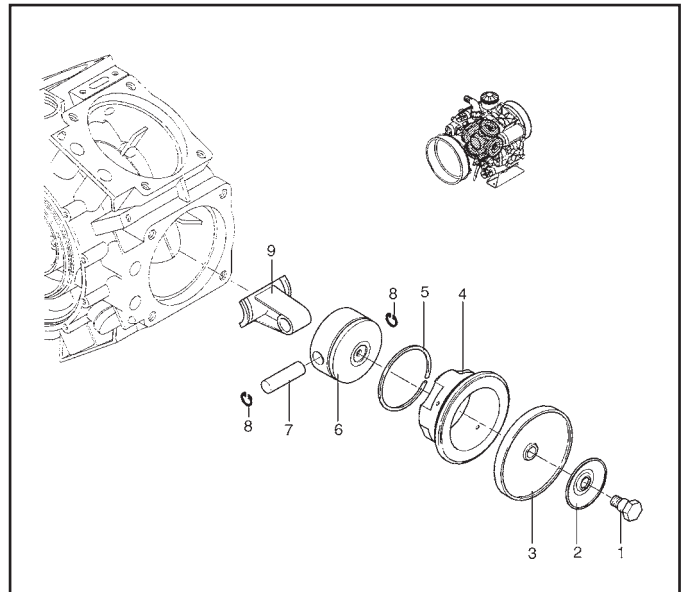
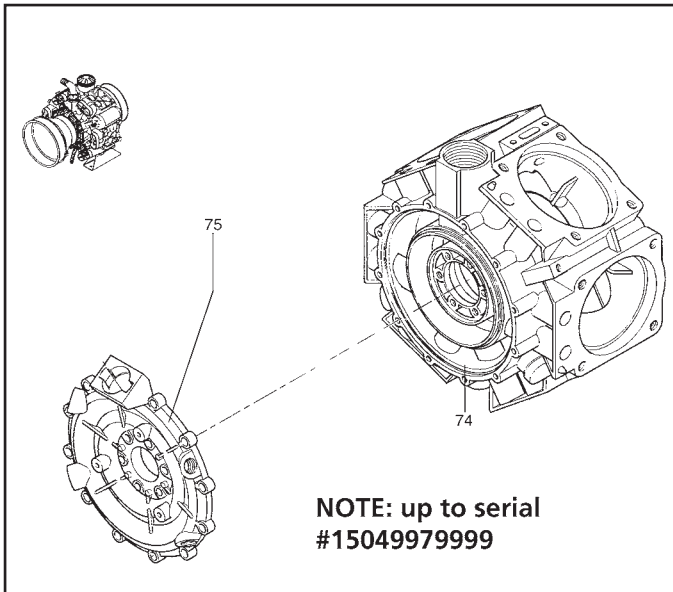
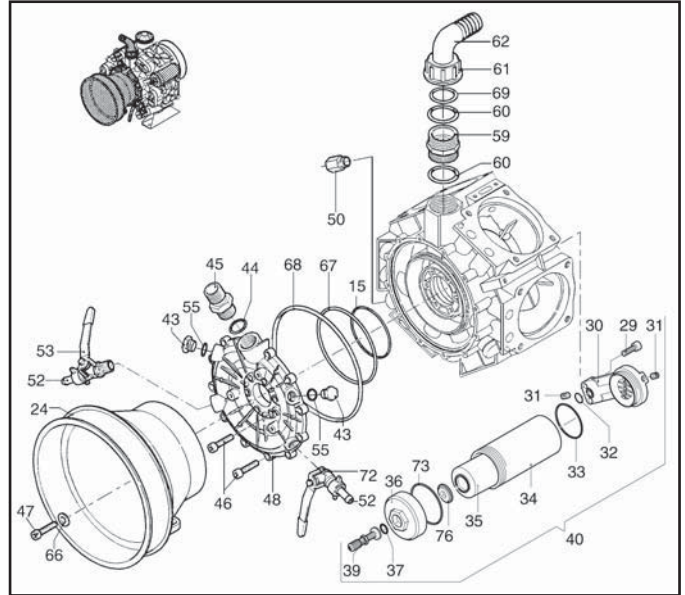
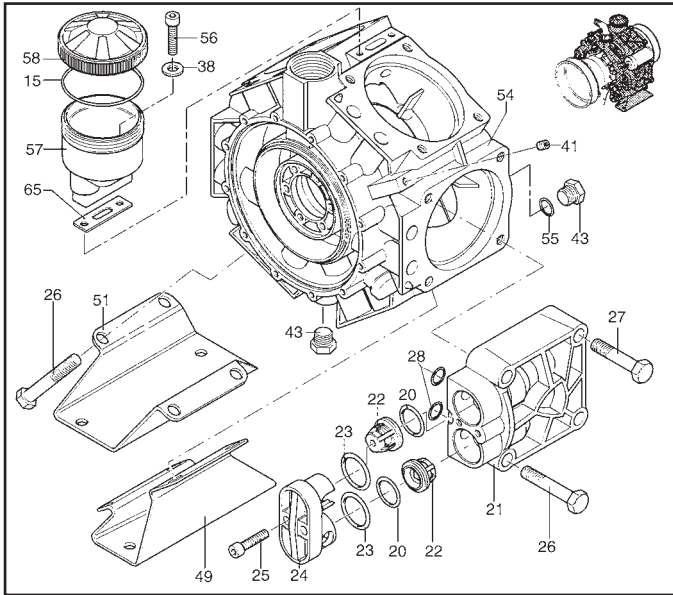

## Parts List for Model 9910-D1516

REF. NO.	PART NUMBER	DESCRIPTION	QTY. REQ'D.
1	9910-580360	Retaining bolt	6
2	9910-1040180	Diaphragm retainer washer	6
3	9910-1040080	Diaphragm, Desmopan (Std.)	6
3A	9910-1040081	Diaphragm, Buna-N (Opt.)	6
3B	9910-104008T	Diaphragm, Buna-N with Teflon Coating (Opt.)	6
4	9910-1500080	Piston sleeve	6
5	9910-650190	Piston ring	6
6	9910-1040120	Piston	6
7	9910-1040070	Connecting pin	6
8	9910-1040270	Snap ring	12
9	9910-1500160	Connecting rod	6
10	9910-1500181	Retaining ring	2
11	9910-820670	Bolt	4
12	9910-180030	Bolt	8
13	9910-1500470	Shield	1
14	9910-1400030	Flange	1
15	9910-1040060	O-ring	3
16	9910-160740	Oil seal	1
17	9910-1500290	Bearing	2
18	9910-1500310	Spacer	1
19	9910-1400310	Crankshaft	1
20	9910-620030	O-ring	12
21	9910-1040551	Head-Right (DX)	3
21	9910-1040552	Head-Left (SX)	3
22	9910-1409050	Valve assembly	12
23	9910-540361	O-ring	12
24	9910-1300190	Valve retainer	6
25	9910-620610	Bolt	12
26	9910-1500230	Bolt	20
27	9910-1500240	Bolt	4
28	9910-770571	O-ring	12
29	9910-320360	Bolt	2
30	9910-1800320	Mount	1
31	9910-1040470	Plug	2
32	9910-640070	O-ring	1
33	9910-540360	O-ring	1
34	9910-1800280	Damper body	1
35	9910-1800300	Diaphragm	1
36	9910-1800270	Cap	1
37	9910-650542	O-ring	1
38	9910-380241	Washer	2
39	9910-1800350	Air valve	1
40	9910-KIT1538	Pulsation damper assembly	1
41	9910-770070	Plug	1
42	9910-1040050	Oil seal	1
43	9910-880530	Plug	2
44	9910-390180	O-ring	1
45	9910-850740	Threaded adapter	1
46	9910-540290	Bolt	18
47	9910-1343510	Bolt	3
48	9910-1840140	Manifold	1
49	9910-1500040	Right base	1
50	2406-0023	Plug	1
51	9910-1500050	Left base	1
52	9910-110130	Hose barb 1/2"	2
53	9910-130491	Outlet ball valve w/o barb	1
54	9910-1500480	Pump body	1
55	9910-740290	O-ring	3
56	9910-680350	Bolt	2
57	9910-750030	Oil reservoir	1
58	9910-1800060	Black cap	1

REF. NO.	PART NUMBER	DESCRIPTION	QTY. REQ'D.
59	9910-540530	Threaded adapter	1
60	9910-250310	O-ring	2
61	9910-540540	Hose barb nut	1
62	9910-540550	Hose barb 1-1/2"	1
63	9910-1500320	O-ring	2
64	9910-1500170	Bearing	2
65	9910-750040	Gasket	1
66	9910-881710	Washer	3
67	9910-851360	O-ring	1
68	9910-1400290	O-ring	1
69	9910-390210	O-ring	1
70	9910-1400090	Spacer	2
71	9910-1500330	Spacer (0.1 mm)	1
71	9910-1500340	Spacer (0.2 mm)	1
72	9910-130492	Outlet ball valve w/barb	1
73	9910-650560	Dampener o-ring	1
74	9910-1500011	Pump body	1
75	9910-1400280	Manifold	1
76	9910-1800310	Plate	1

Ref. No.	Description	Tightening Torque	
		In. Lbs.	Nm
1	Bolt	262.5	29.4
11	Bolt	87.5	9.8
12	Bolt	171.4	19.6
25	Bolt	171.4	19.6
26	Bolt	435.5	49.0
27	Bolt	435.5	49.0
29	Bolt	171.4	19.6
43	Plug	171.4	19.6
46/47	Bolt	87.5	9.8
50	Plug	171.4	19.6
56	Bolt	87.5	9.8



**9910-KIT2113**  
**Diaphragm Kit**  
**Desmopan**

Ref. No.	Qty.
3	6
28	12



**9910-KIT2053**  
**Valve Kit**

Ref. No.	Qty.
20	12
22	12
23	12

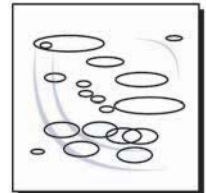

**9910-KIT2349**  
**O-Ring Kit**

Ref. No.	Qty.
15	3
20	12
23	12
28	12
32	1
33	1
44	1
55	3
60	2
67	1
68	1
69	1

NOTE: When ordering parts, give QUANTITY, PART NUMBER, DESCRIPTION, and COMPLETE PUMP MODEL NUMBER. Reference numbers are used ONLY to identify parts in the drawing and are NOT to be used as order numbers.