

Models 9307C-GM10, 9307C-GM12, 9307C-GM10-U & 9307C-GM12-U

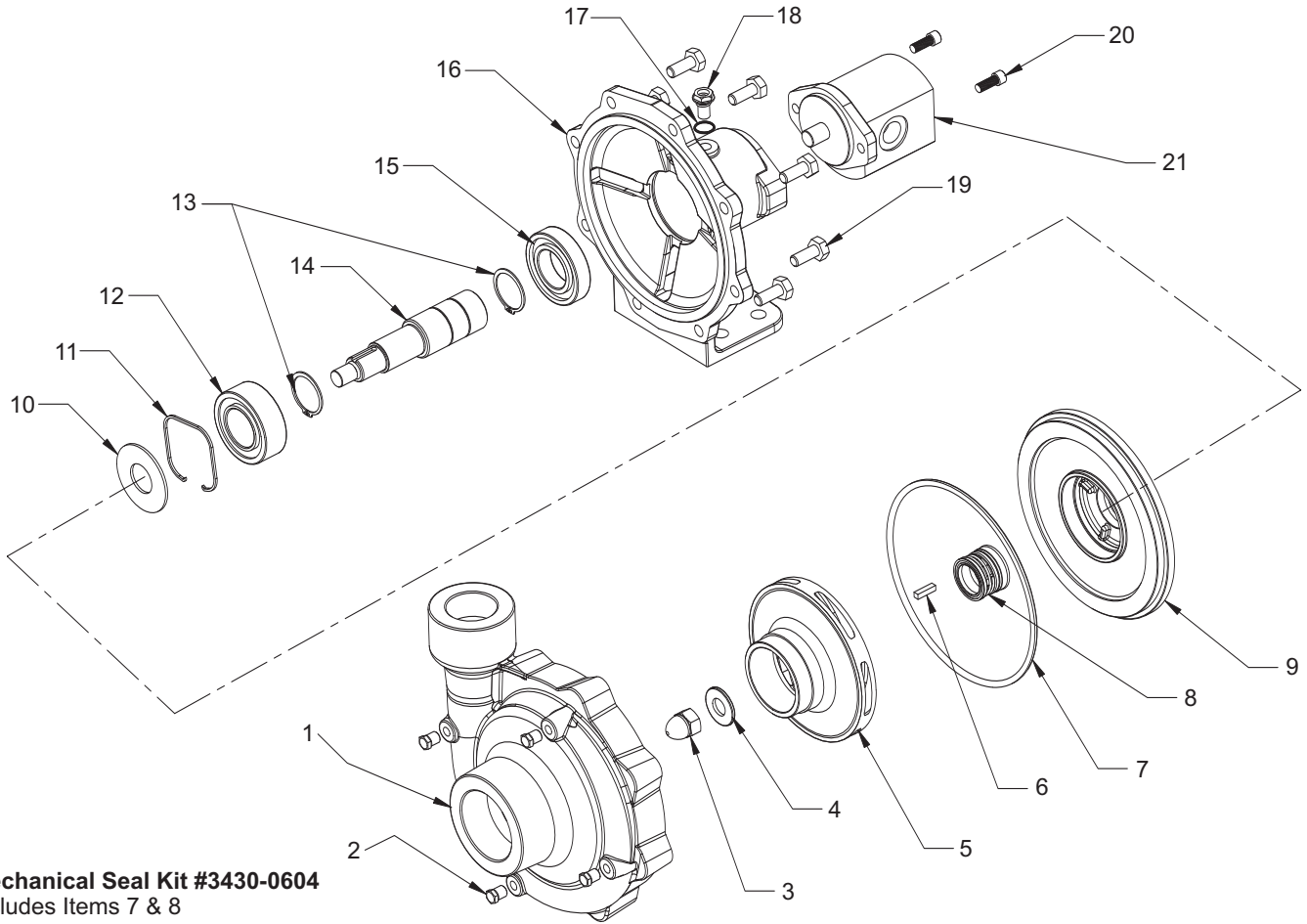

Mechanical Seal Kit #3430-0604
Includes Items 7 & 8

Bearing Kit #3430-0671
Includes Items 10, 11, 12, 13 & 15

Impeller Hardware Kit #3430-0612
Includes Items 3, 4 & 6

Hydraulic Motor Seal Replacement #3430-0611
For seal replacement in Motor #2500-0036 (GM10)

Hydraulic Motor Seal Replacement #3430-0616
For seal replacement in Motor #2500-0046 (GM12)

NOTE: When ordering parts, give quantity, part number, description and complete model number. Reference numbers are used ONLY to identify parts in the drawing and are NOT to be used as order numbers.

Ref. No.	Qty. Req'd	Part No.	Description
1*	1	0150-9300C	Pump Casing
1**	1	0151-9300C	Pump Casing (Universal Flange)
2	4	2406-0039	Pipe Plug
3	1	2253-0010	Acorn Nut
4	1	2270-0094	Washer
5	1	0400-9300S	Impeller
6	1	1610-0058	Key
7	1	1721-0208	O-Ring
8	1	2120-0043	Mechanical Seal
9	1	0755-9300C	Seal Flange
10	1	2270-0093	Slinger
11	1	1820-0040	Retaining Ring

Ref. No.	Qty. Req'd	Part No.	Description
12	1	2005-0006	Double Row Ball Bearing
13	2	1810-0001	Retaining Ring
14	1	0500-9305	Shaft Assembly
15	1	2007-0063	Ball Bearing
16	1	0757-9300C	Mounting Flange
17	1	1720-0209	O-Ring
18	1	2300-0040	Plug
19	8	2210-0131	Bolt
20	2	2210-0026	Bolt
21	1	2500-0036	Hydraulic Motor (GM10)
21	1	2500-0046	Hydraulic Motor (GM12)

*Includes a Stainless Steel Wear Ring and 4 Pipe Plugs (Ref. No. 2)

**Used in -U "Universal Flange" models, includes Stainless Steel Wear Ring and 4 Pipe Plugs (Ref. No. 2)