

2120 Plunger Series

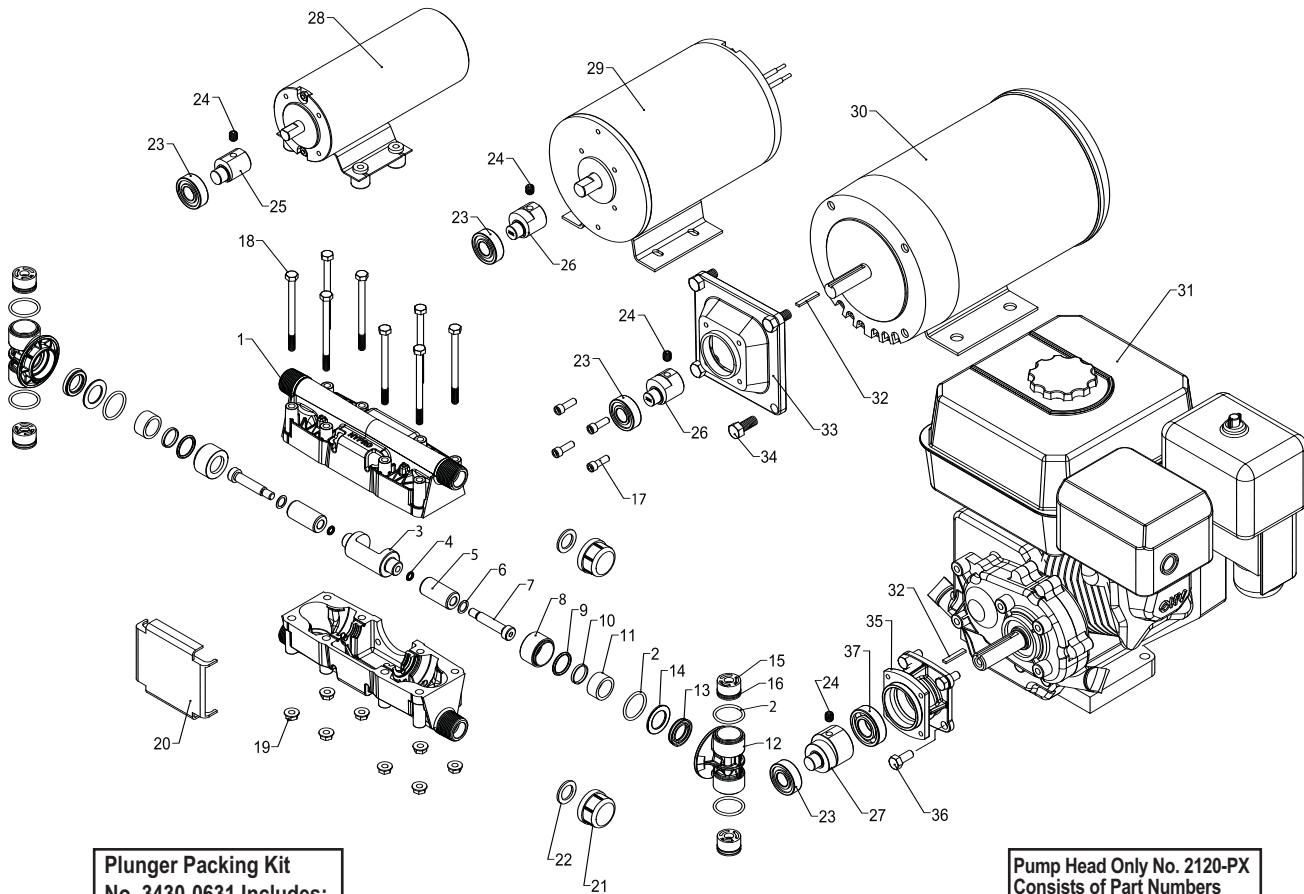

**Plunger Packing Kit
No. 3430-0631 Includes:**

Ref. No.	Qty.
2	6
4	2
6	2
9	2
10	2
11	2
13	2

**Plunger Pump Valve Kit
No. 3430-0632 Includes:**

Ref. No.	Qty.
2	4
15	4
16	4

**Engine Flange Mounting
Kit No. 3430-0658 Includes:**

Ref. No.	Qty.
32	1
35	1
36	4
37	1

**Pump Head Only No. 2120-PX
Consists of Part Numbers
1 thru 22.**

Note: When ordering parts, give quantity, part number, description and complete model number. Reference numbers are used ONLY to identify parts in the drawing and NOT to be used as order numbers.

Ref. No.	Qty. Req'd.	Part No.	Description	Ref. No.	Qty. Req'd.	Part No.	Description
1	2	0101-2100PM	Pump Body (Polyester PBT)	21	2	2102030	End Cap
2	6	1720-0076	O-ring	22	2	G40013	End Cap Washer
3	1	0500-2100	Connecting Rod	23	1	2000-0015	Bearing
4	2	1720-0033	O-ring	24	1	2230-0003	Set Screw
5	2	3500-0070	Ceramic Plunger (3/4" in. Dia.)	25	1	0550-2145	Shaft Eccentric (2120P-P18DC)
6	2	2270-0015	Seal Washer	26	1	0551-2175	Shaft Eccentric (2120P-P35DC, P50AC)
7	2	2220-0104	Shoulder Screw	27	1	0552-2190	Shaft Eccentric (Gas Engine)
8	2	1830-0171	Guide Retainer	28	1	2570-0025	DC Motor (20 Amp)
9	2	1720-0202	O-ring	29	1	2570-0026	DC Motor (36 Amp)
10	2	1440-0010	Seal Ring	30	1	2560-0013	Motor (1/2 HP, 56C Frame AC, 50 Hz)
11	2	1440-0086	Plunger Guide (Carbon)	30	1	2570-0027	Motor (1/2 HP, 56C Frame DC, 39 Amp)
12	2	0717-2100P	Valve Retainer	30	1	21721	Motor (1/2 HP, 56C Frame AC, 60 Hz)
13	2	2150-0091	U-Cup Seal (Viton)	31	1	2549-0052	Gas Engine (2:1 Gear Reduced)
14	2	2270-0095	U-Cup Backup Ring	32	1	1610-0061	Key
15	4	3400-0088	Valve Assembly	33	1	0706-2100A	Adapter Flange (56C Motor)
16	4	1720-0007	O-ring	34	4	2210-0020	Bolts
17	4	2220-0041	Hex Head Cap Screw	35	1	0708-2100A	Adapter Flange (Gas Engine)
18	8	2210-0137	Bolts	36	4	2210-0146	Bolts
19	8	2250-0077	Flanged Nuts	37	1	2000-0017	Bearing
20	1	2840-0083	Nameplate				